

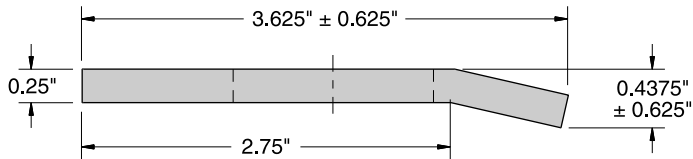

Anchor Brackets

For Pad-Mount Enclosures

Descriptive Bulletin
6102
 Page 1 2015

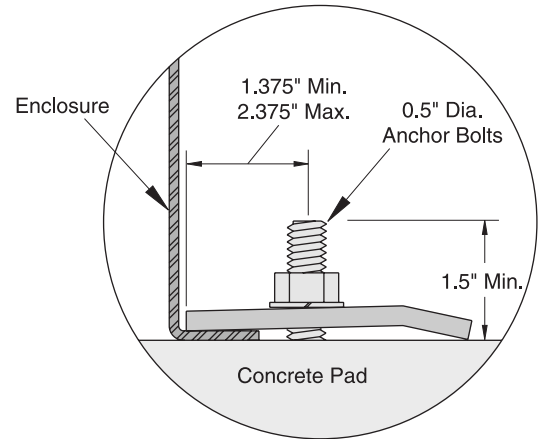
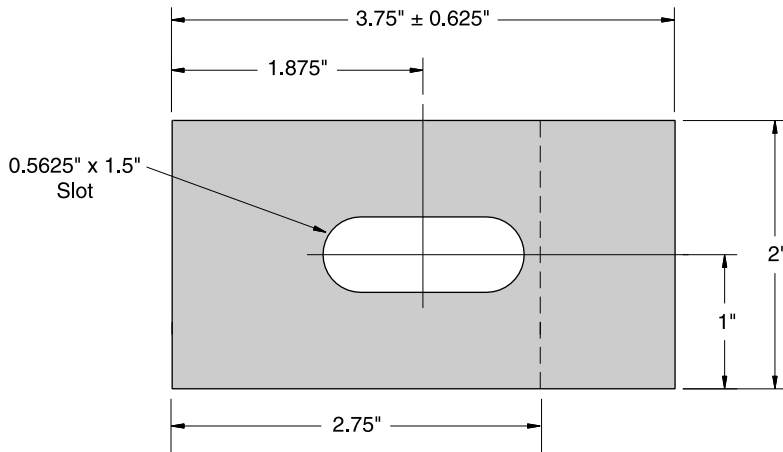

Catalog Number	Description	Material
6102-A81-7	Anchor Bracket	#6061-T6 Aluminum
6102-A81-8	Anchor Bracket	#304 Stainless Steel



Anchor Brackets
For Pad-Mount Enclosures

Descriptive
Bulletin
6102
Page 2 2015

**If you do not find the design
you need**

PLEASE CONTACT

our REPRESENTATIVE or the FACTORY