



25-kV Apparatus Bushings

“C” Series (bolt-in) for Elbow to Air Insulated Service

200 Amp

Descriptive
Bulletin
1301
Page 1 2008

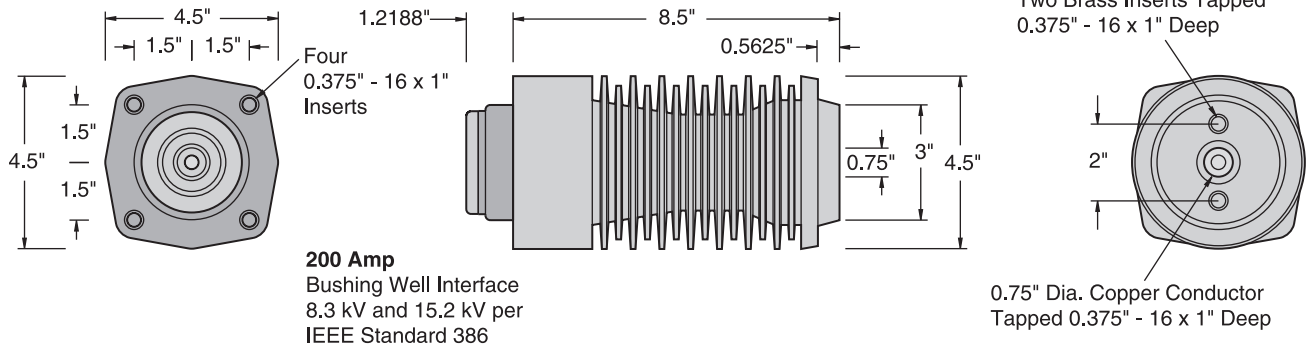

Bushings Well #1301-225C

<p>Voltage Class..... 25 kV</p> <p>Phase-to-Ground Voltage..... 15.2 kV</p> <p>BIL..... 125 kV</p> <p>A.C. Withstand - 1 Min. Dry..... 40 kV</p> <p style="padding-left: 20px;">10 Sec. Dew..... 40 kV</p> <p>D.C. Withstand - 15 Min. Dry..... 78 kV</p> <p>Corona Extinction Level - Minimum..... >19 kV</p> <p>Continuous Current..... 200 Amps</p> <p>Momentary - RMS, Sym., 0.17 sec..... 10,000 Amps</p> <p style="padding-left: 20px;">RMS, Sym., 3 sec..... 3,500 Amps</p>	<p>Leakage Distance, Inches..... 28</p> <p>Dry Arcing Distance, Inches..... 8.5</p> <p>Mechanical - Strength Rating, Pounds</p> <p style="padding-left: 20px;">Cantilever, Ultimate 2.5 inches past end..... >1,000</p> <p style="padding-left: 20px;">Tensile, Pounds..... >5,000</p> <p style="padding-left: 20px;">Torsion, Inches-Pounds (bolt breaks)..... >1,000</p> <p style="padding-left: 20px;">Compression, Pounds..... 20,000</p> <p>Insert Thread Size..... 0.375" - 16 x 1"</p> <p>Conductor (live end) Thread Size..... 0.375" - 16 x 1"</p> <p>Net Weight, Pounds (kg)..... 6.75 (3.06)</p>
---	--

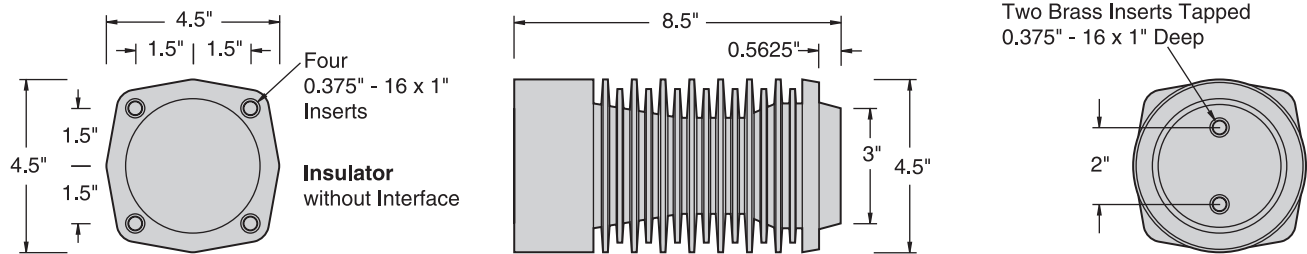

“Bushings-Style” Insulator #1801-025C

<p>Voltage Class..... 25 kV</p> <p>Phase-to-Ground Voltage..... 15.2 kV</p> <p>BIL..... 125 kV</p> <p>A.C. Withstand - 1 Min. Dry..... 40 kV</p> <p style="padding-left: 20px;">10 Sec. Dew..... 40 kV</p> <p>D.C. Withstand - 15 Min. Dry..... 78 kV</p> <p>Corona Extinction Level - Minimum..... >19 kV</p> <p>Continuous Current..... N/A</p> <p>Momentary - RMS, Sym., 0.17 sec..... N/A</p> <p style="padding-left: 20px;">RMS, Sym., 3 sec..... N/A</p>	<p>Leakage Distance, Inches..... 28</p> <p>Dry Arcing Distance, Inches..... 8.5</p> <p>Mechanical - Strength Rating, Pounds</p> <p style="padding-left: 20px;">Cantilever, Ultimate 2.5 inches past end..... >1,000</p> <p style="padding-left: 20px;">Tensile, Pounds..... >5,000</p> <p style="padding-left: 20px;">Torsion, Inches-Pounds (bolt breaks)..... >1,000</p> <p style="padding-left: 20px;">Compression, Pounds..... 20,000</p> <p>Insert Thread Size..... 0.375" - 16 x 1"</p> <p>Live End Thread Size..... 0.375" - 16 x 1"</p> <p>Net Weight, Pounds (kg)..... 5.82 (2.64)</p>
---	--

Production Tests

Every bushing is production tested in free air, mounted in an 11-gauge grounded steel plate not less than 10 inches x 10 inches, with an insulating protective plug (or cap) installed on the interface to accurately simulate operating conditions. Each bushing must meet or exceed the requirements for 15.2/26.3 kV devices in accordance with the test values of IEEE Standard 386 (latest revision) for partial discharge (corona) and A.C. voltage withstand when tested in this manner.

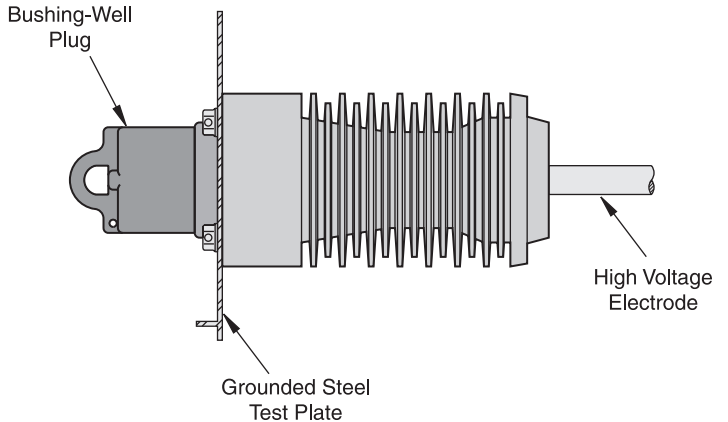

Installation Instructions

Elliott "B" Series Apparatus Bushings require a 3.125" diameter mounting hole with four 0.4375" diameter bolt holes. The bushing bolts in place utilizing four 0.375-inch -16 x 1" serrated flange hex head bolts (or bolts with external tooth lock washers). All mounting hardware is located on the elbow side of the equipment mounting plate to eliminate the possibility of reduced phase-to-ground clearance.

Every Elliott Bushing is tested at the factory, mounted in a grounded steel plate. A greased bushing well plug (or insulating protective cap) is installed on the interface to accurately simulate operating conditions. To prevent contamination of the silicone grease, it is important to keep the shipping cap in place until you are ready to install the bushing insert. Should the grease become contaminated, thoroughly clean the interface and reapply silicone grease before installing the bushing insert.

NOTE: The shipping cap should be left in place to prevent contamination of the interface.

1. The bushing installs from the rear (live) side for easy installation.
2. Serrated flange bolts (or bolts and external tooth lock washers) are installed. The bolts should be tightened in a uniform manner (rather than one-by-one in a random sequence). Do not apply more than 90 inch-pounds torque to each bolt. The serrated flange bolts (or external tooth lock washers) must "cut" into the mounting plate to provide a connection from the shielding to the grounded mounting plate. If the bushing is mounted on an ungrounded or insulated plate (such as fiberglass) a ground strap should be attached to one of the mounting bolts.

IMPORTANT:

Do not energize this bushing with only the shipping cap in place. To do so would lead to failure of the bushing and create a hazard to operating personnel. *This product is designed to be used only when it is mated with an appropriate 15 kV or 25 kV class bushing insert (or elbow) conforming to the latest revision of IEEE Standard 386.* The bushing insert (or elbow) should be installed in accordance with the instructions supplied by the connector manufacturer.

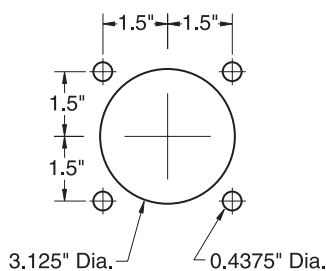

Standard Mounting Holes for Elliott "B" Series Bushings

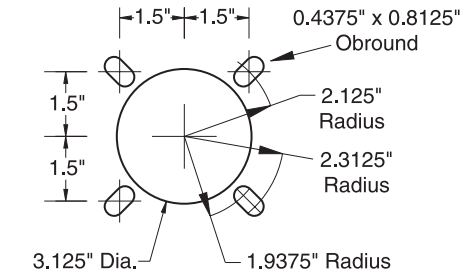

Uni-Mount Mounting Holes Accepts Elliott and S&C Bushings

