

For 35-kV Connectors (Elbows)

Elliott "B" Series (bolt-in) apparatus bushings are used to construct air-insulated equipment that connects to the utility's underground shielded cable system with IEEE Standard separable insulated connectors (i.e. elbows). The same 5-hole mounting provision accommodates all "B" Series bushings. Integral shielding prevents "edge-of-hole" corona discharge. The live side of the bushing is provided with unique square-edge skirts and increased leakage distance to resist flashover when severely contaminated and wet. The large diameter live end terminal pad (with female threads) provides for direct contact of current-carrying parts and eliminates exposed sharp threads, which could induce destructive corona discharge. The heavy-duty flange provides exceptionally high cantilever strength so bushings can be used to provide physical support for energized parts. In addition to IEEE Standard 386 design tests, Elliott bushings are design tested for thermal cycle withstand from +200° to -200° F to assure long field life. Every bushing is production tested "in-air" mounted in a grounded steel plate with an insulated protective plug (or cap) installed on the interface to accurately simulate operating conditions.

ELRIM Cycloaliphatic Epoxy Provides:

- Nontracking, self-scouring, nonweathering performance
- Superior dielectric strength, dielectric loss and power factor
- Choice of shapes allows design innovation
- Mechanical and thermal toughness
- Shatter free arc flashover performance
- Oil resistant

Elliott Design Provides:

- Precision molded interfaces per IEEE Standard 386 "Bolt-In" design
- Integral shielding to prevent destructive corona discharge
- Increase leakage distance and square-edge skirts resist contamination - wet or dry
- Generous dry arcing (strike) distance
- Large diameter live end terminal pad with female threads for direct contact of current-carrying parts and improved corona performance
- Thermal cycle withstand from +200° to -200° F for long life
- High Strength - field proven performance since 1975

Ratings and Dimensions of Bushing Wells & Bushings

Catalog Number	Voltage Class kV	Continuous Current Amps	Withstand Test Voltage Kilovolts			Minimum Leakage Inches	Minimum Strike Inches
			Impulse 1.2 x 50	One Min. Dry	10 Sec. Dew		
1102-235B3 Bushing Well	35	200	200	75	50	46	13
1202-635B3 Bushing	35	600	200	75	50	46	13
1203-935B3 Bushing	35	900	200	75	50	46	13
1204-1235B3 Bushing	35	1250 Special Order	200	75	50	46	13
1802-035B3 Insulator	35	N/A	200	75	50	46	13

Elastimold® is a registered trademark of ABB Asea Brown Boveri Ltd.

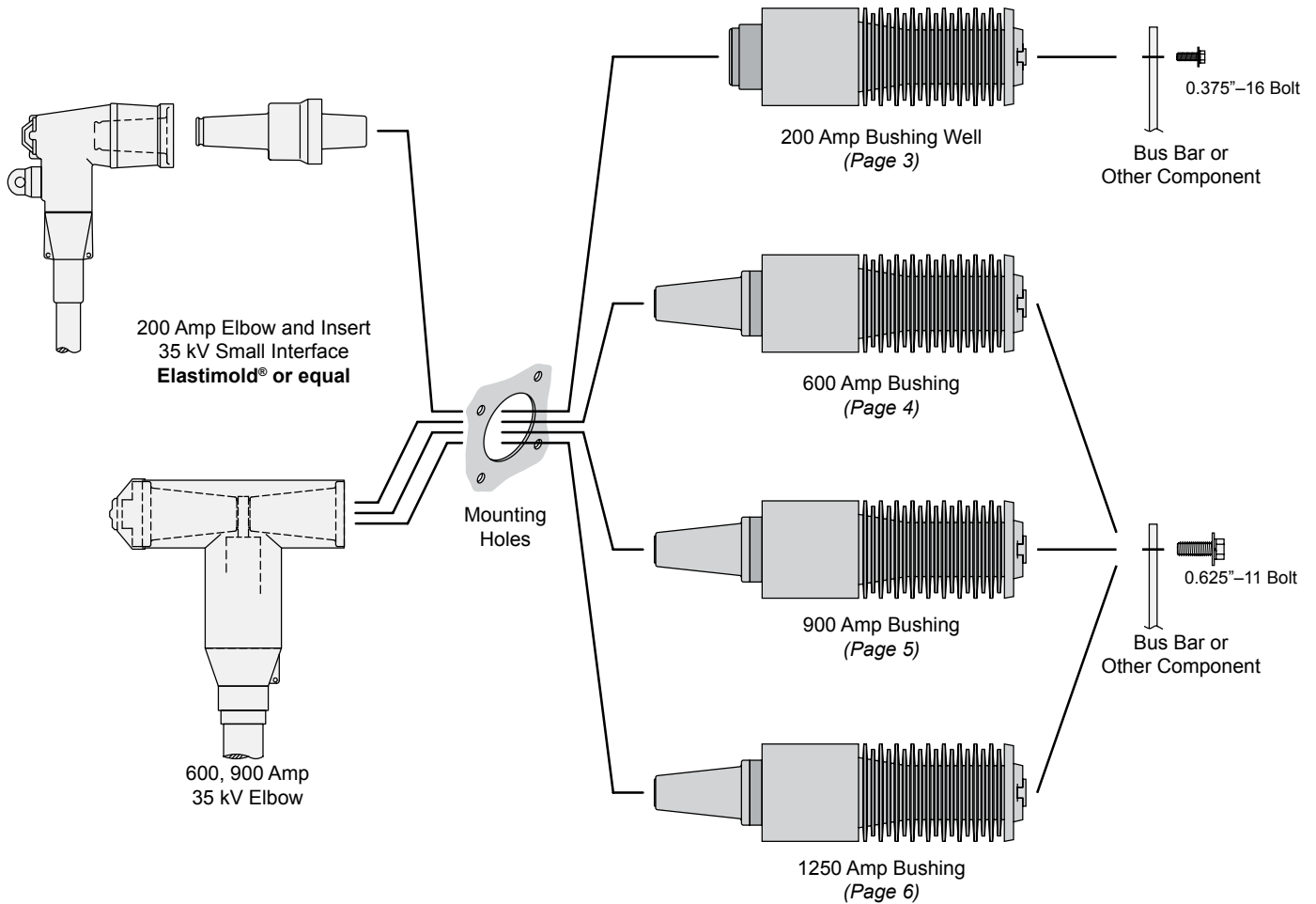

Common Mounting - All "B" Series bushings have the same mounting bolt pattern. The installer can punch one mounting hole pattern and install any "B" Series bushing or insulator. For example, equipment can be designed for 600 amp bushings, but actually be assembled with 600 and 200 amp bushings. A bushing-style insulator can be used to support one end of a bus bar and be replaced in the field with a 200 or 600 amp bushing.

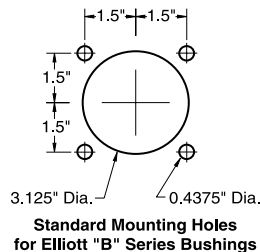

Index Slots - Elliott "B" Series bushings and insulators feature four keying slots on the live end. Fuse clips and hinge kits are available that bolt directly to the bushing conductor and key in the slots to prevent rotation.

Conductor Connection - Female threads in the live end of the conductor allow the attachment of live parts of almost any thickness. The bolted connection of current-carrying parts does not depend on current transfer through the fastener's thread-to-thread contact. Additional advantages of the bolted connection are higher clamping pressure and elimination of exposed sharp threads that could initiate corona.

200 Amp Bushing Well #1102-235B3

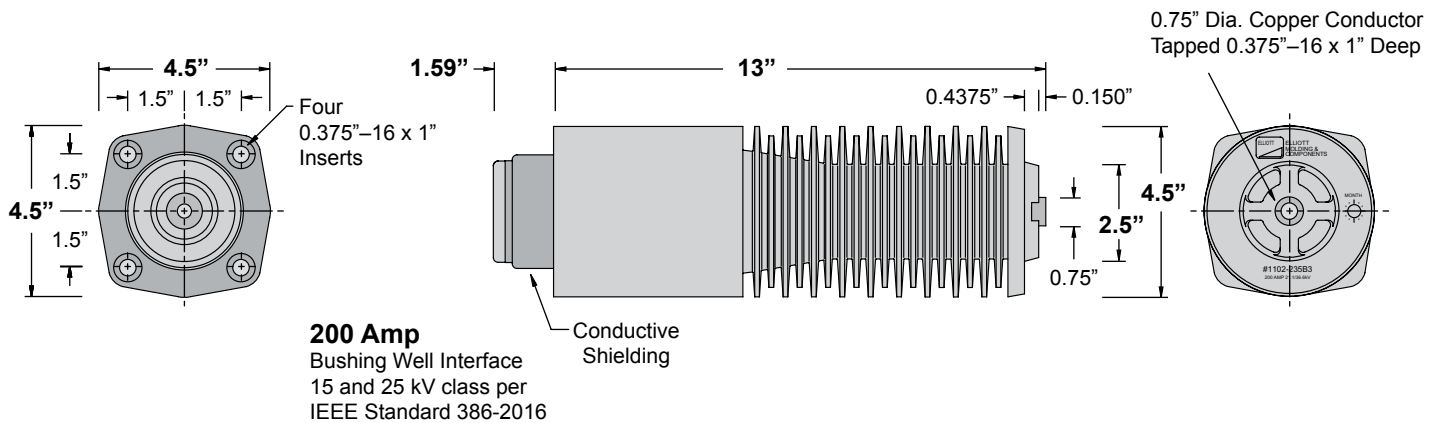

Voltage Class.....	35 kV
Phase-to-Ground Voltage.....	21.1 kV
BIL.....	200 kV
AC Withstand - 1 Min. Dry.....	75 kV
10 Sec. Dew.....	50 kV
DC Withstand - 15 Min. Dry.....	103 kV
Corona Extinction Level - Minimum.....	26 kV
Continuous Current.....	200 Amps
Momentary - RMS, Sym., 0.17 sec.....	10,000 Amps
RMS, Sym., 3 sec.....	3,500 Amps

Leakage Distance, Inches.....	46
Dry Arcing Distance, Inches.....	13
Mechanical - Strength Rating, Pounds	
Cantilever, Ultimate 2.5 inches past end.....	>1,000
Tensile, Pounds.....	>5,000
Torsion, Inches-Pounds (bolt breaks).....	>700
Compression, Pounds.....	20,000
Insert Thread Size.....	0.375"–16 x 1"
Conductor (live end) Thread Size.....	0.375"–16 x 1"
Net Weight, Pounds (kg).....	12.85 (5.83)

Typical Specifications - 200 Amp 35-kV 200-kV BIL Bushing Wells

Bushings shall be 200 ampere Elliott #1102-235B3, 35 kV Class (21.1 kV to ground) Air-Insulated Bushing Wells, 200 kV BIL, per IEEE Standard 386-2016 Fig. 3 (Interface 3: a 200 A bushing well interface) for use with 21.1/36.6 kV separable insulated connectors (Elastimold® or other approved equal). The bushing wells shall be pressure-molded cycloaliphatic epoxy with a 0.75-inch diameter copper conductor on the “air-insulated” side that is drilled and tapped 0.375-inch–16UNC x 1-inch deep to provide direct connection of the bus and/or live parts. Leakage distance from the apparatus connection end of the bushing well to ground shall be not less than 43 inches to assure trouble-free operation in a wet and/or contaminated environment. Integral shielding shall be provided to eliminate partial discharge caused by off-center mounting and mounting holes that may have sharp edges or burrs. Bushing wells shall mount in a 3.125-inch diameter opening and bolt in place to allow field replacement with standard

tools. The bushing mounting bolts shall be self-locking stainless steel serrated-flange hex-head bolts that “cut” through the enclosure protective finish to ground the integral shielding of each bushing. To assure adequate strength for apparatus support, the bushing well shall withstand a minimum cantilever loading of 600 pounds for five minutes without damage. The bushing well interface shall be free of all voids, holes and heat sinks to assure proper mating with separable insulated connectors. Each bushing well shall be tested in free air, mounted in a grounded steel plate not less than 10 inches x 10 inches, and with a bushing well plug (Elastimold® #M276BWP or equal) installed in the well interface to accurately simulate operating conditions (*gas or liquid dielectric in the interface shall not be acceptable for this test*). Each bushing well shall meet the requirements for 35 kV devices in accordance with IEEE Standard 386 (latest revision), including 100 percent production testing.

Elastimold® is a registered trademark of ABB Asea Brown Boveri Ltd.



35-kV 200-kV BIL Apparatus Bushings

“B” Series (bolt-in) for Elbow to Air-Insulated Service
200 Amp, 600 Amp, 900 Amp and 1250 Amp

Descriptive Bulletin
1035-230
Page 4 2019

600 Amp Bushing #1202-635B3

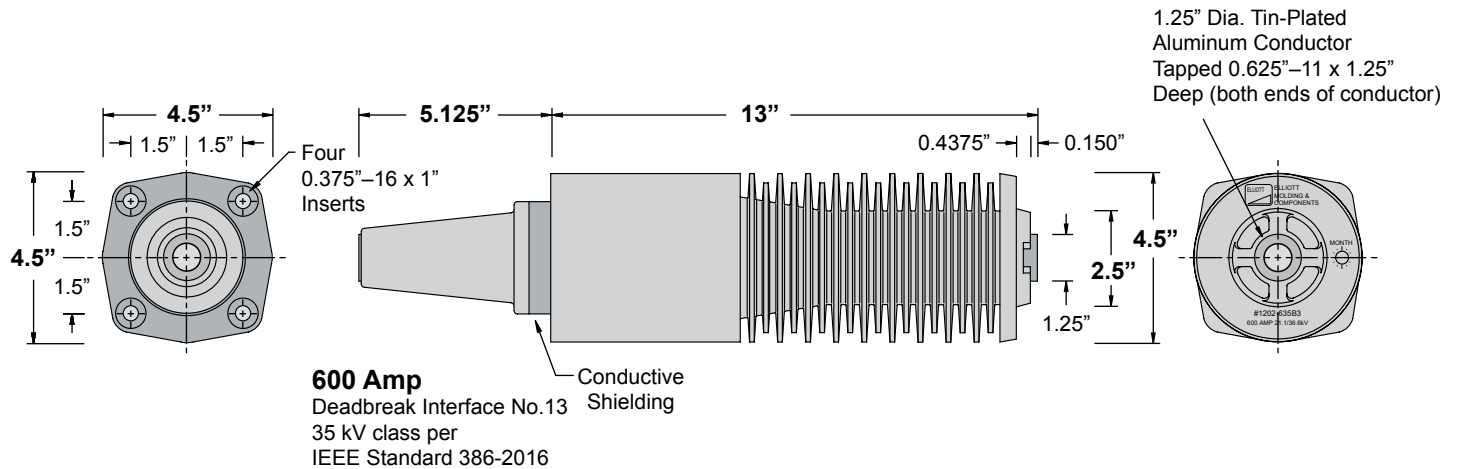

Voltage Class.....	35 kV
Phase-to-Ground Voltage.....	21.1 kV
BIL.....	200 kV
AC Withstand - 1 Min. Dry.....	75 kV
10 Sec. Dew.....	50 kV
DC Withstand - 15 Min. Dry.....	103 kV
Corona Extinction Level - Minimum.....	26 kV
Continuous Current.....	600 Amps
Momentary - RMS, Sym., 0.17 sec.....	25,000 Amps
RMS, Sym., 3 sec.....	10,000 Amps

Leakage Distance, Inches.....	46
Dry Arcing Distance, Inches.....	13
Mechanical - Strength Rating, Pounds	
Cantilever, Ultimate 2.5 inches past end.....	>1,000
Tensile, Pounds.....	>5,000
Torsion, Inches-Pounds (bolt breaks).....	>3,500
Compression, Pounds.....	20,000
Insert Thread Size.....	0.375"–16 x 1"
Conductor (live end) Thread Size.....	0.625"–11 x 1.25"
Net Weight, Pounds (kg).....	12.50 (5.61)

Typical Specifications - 600 Amp 35-kV 200-kV BIL Bushings

Bushings shall be 600 ampere Elliott #1202-635B3, 35 kV Class (21.1 kV to ground) Air-Insulated Bushings, 200 kV BIL, per IEEE Standard 386-2016 Fig. 15 (Interface 13: a 600 and 900 A deadbreak interface, 35 kV class) for use with 21.1/36.6 kV separable insulated connectors (Elastimold®, Eaton's Cooper Power Systems or other approved equal). The bushings shall be pressure-molded cycloaliphatic epoxy with a 1.25-inch diameter tin-plated aluminum conductor on the "air-insulated" side that is drilled and tapped 0.625-inch–11UNC x 1-inch deep to provide direct connection of the bus and/or live parts. Leakage distance from the apparatus connection end of the bushing to ground shall be not less than 43 inches to assure trouble-free operation in a wet and/or contaminated environment. Integral shielding shall be provided to eliminate partial discharge caused by off-center mounting and mounting holes that may have sharp edges or burrs. Bushings shall mount in a 3.125-inch diameter opening and bolt in place to allow

field replacement with standard tools. The bushing mounting bolts shall be self-locking stainless steel serrated-flange hex-head bolts that "cut" through the enclosure protective finish to ground the integral shielding of each bushing. To assure adequate strength for apparatus support, the bushing shall withstand a minimum cantilever loading of 600 pounds for five minutes without damage. The bushing interface shall be free of all voids, holes and heat sinks to assure proper mating with separable insulated connectors. Each bushing shall be tested in free air, mounted in a grounded steel plate not less than 10 inches x 10 inches, and with an insulated protective cap (Eaton's Cooper Power Systems #DPC635 or equal) installed on the interface to accurately simulate operating conditions (gas or liquid dielectric on the interface shall not be acceptable for this test). Each bushing shall meet the requirements for 35 kV devices in accordance with IEEE Standard 386 (latest revision), including 100 percent production testing.

Elastimold® is a registered trademark of ABB Asea Brown Boveri Ltd.

900 Amp Bushing #1203-935B3

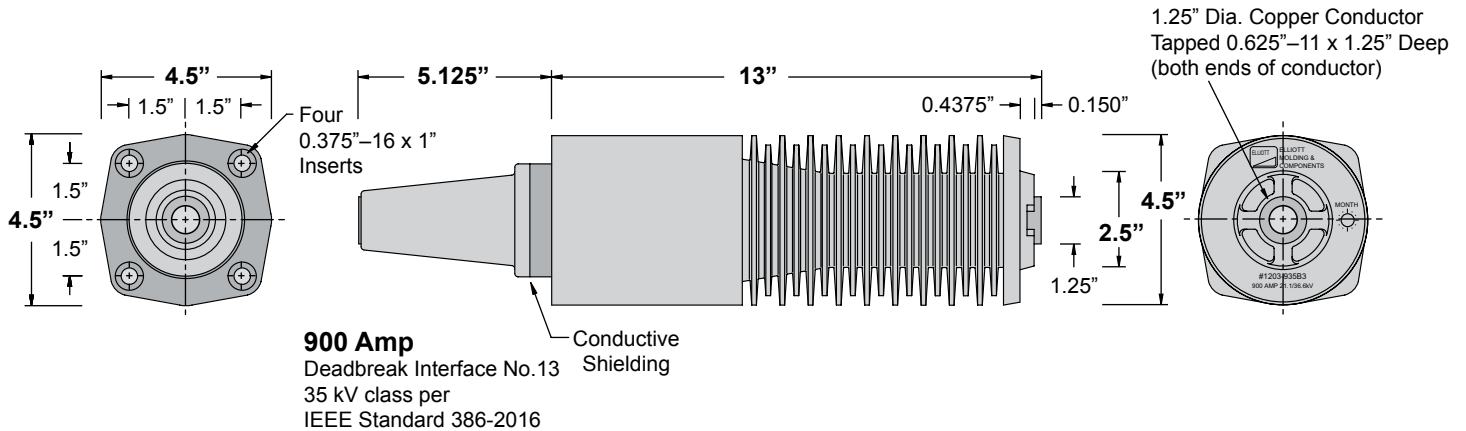

Voltage Class.....	35 kV
Phase-to-Ground Voltage.....	21.1 kV
BIL.....	200 kV
AC Withstand - 1 Min. Dry.....	75 kV
10 Sec. Dew.....	50 kV
DC Withstand - 15 Min. Dry.....	103 kV
Corona Extinction Level - Minimum.....	26 kV
Continuous Current.....	900 Amps
Momentary - RMS, Sym., 0.17 sec.....	25,000 Amps
RMS, Sym., 3 sec.....	10,000 Amps

Leakage Distance, Inches.....	46
Dry Arcing Distance, Inches.....	13
Mechanical - Strength Rating, Pounds	
Cantilever, Ultimate 2.5 inches past end.....	>1,000
Tensile, Pounds.....	>5,000
Torsion, Inches-Pounds (bolt breaks).....	>3,500
Compression, Pounds.....	20,000
Insert Thread Size.....	0.375"–16 x 1"
Conductor (live end) Thread Size.....	0.625"–11 x 1.25"
Net Weight, Pounds (kg).....	17.50 (7.94)

Typical Specifications - 900 Amp 35-kV 200-kV BIL Bushings

Bushings shall be 900 ampere Elliott #1203-935B3, 35 kV Class (21.1 kV to ground) Air-Insulated Bushings, 200 kV BIL, per IEEE Standard 386-2016 Fig. 15 (Interface 13: a 600 and 900 A deadbreak interface, 35 kV class) for use with 21.1/36.6 kV separable insulated connectors (Elastimold®, Eaton's Cooper Power Systems or other approved equal). The bushings shall be pressure-molded cycloaliphatic epoxy with a 1.25-inch diameter copper conductor on the "air-insulated" side that is drilled and tapped 0.625-inch–11UNC x 1-inch deep to provide direct connection of the bus and/or live parts. Leakage distance from the apparatus connection end of the bushing to ground shall be not less than 43 inches to assure trouble-free operation in a wet and/or contaminated environment. Integral shielding shall be provided to eliminate partial discharge caused by off-center mounting and mounting holes that may have sharp edges or burrs. Bushings shall mount in a 3.125-inch diameter opening and bolt in place to allow field

replacement with standard tools. The bushing mounting bolts shall be self-locking stainless steel serrated-flange hex-head bolts that "cut" through the enclosure protective finish to ground the integral shielding of each bushing. To assure adequate strength for apparatus support, the bushing shall withstand a minimum cantilever loading of 600 pounds for five minutes without damage. The bushing interface shall be free of all voids, holes and heat sinks to assure proper mating with separable insulated connectors. Each bushing shall be tested in free air, mounted in a grounded steel plate not less than 10 inches x 10 inches, and with an insulated protective cap (Eaton's Cooper Power Systems #DPC635 or equal) installed on the interface to accurately simulate operating conditions (gas or liquid dielectric on the interface shall not be acceptable for this test). Each bushing shall meet the requirements for 35 kV devices in accordance with IEEE Standard 386 (latest revision), including 100 percent production testing.



35-kV 200-kV BIL Apparatus Bushings

“B” Series (bolt-in) for Elbow to Air-Insulated Service
200 Amp, 600 Amp, 900 Amp and 1250 Amp

Descriptive Bulletin
1035-230
Page 6 2019

1250 Amp Bushing #1204-1235B3

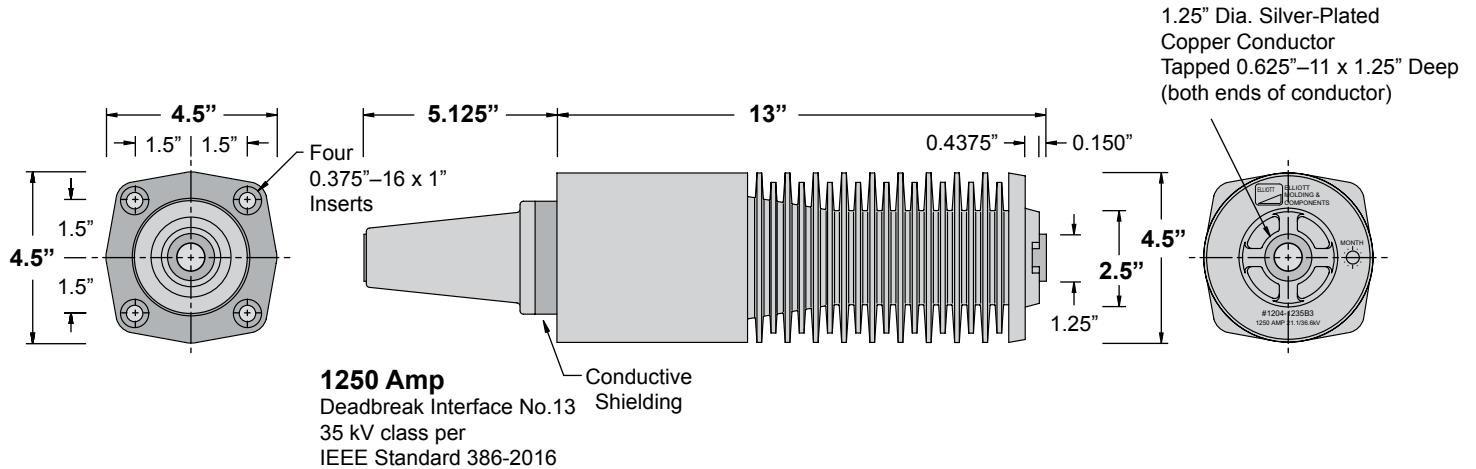

Voltage Class	35 kV
Phase-to-Ground Voltage	21.1 kV
BIL	200 kV
AC Withstand - 1 Min. Dry	75 kV
10 Sec. Dew	50 kV
DC Withstand - 15 Min. Dry	103 kV
Corona Extinction Level - Minimum	26 kV
Continuous Current	1250 Amps
Momentary - RMS, Sym., 0.17 sec	25,000 Amps
RMS, Sym., 3 sec	10,000 Amps

Leakage Distance, Inches	46
Dry Arcing Distance, Inches	13
Mechanical - Strength Rating, Pounds	
Cantilever, Ultimate 2.5 inches past end	>1,000
Tensile, Pounds	>5,000
Torsion, Inches-Pounds (bolt breaks)	>3,500
Compression, Pounds	20,000
Insert Thread Size	0.375"-16 x 1"
Conductor (live end) Thread Size	0.625"-11 x 1.25"
Net Weight, Pounds (kg)	17.50 (7.94)

Typical Specifications - 1250 Amp 35-kV 200-kV BIL Bushings

Bushings shall be 1250 ampere Elliott #1204-1235B3, 35 kV Class (21.1 kV to ground) Air-Insulated Bushings, 200 kV BIL, per IEEE Standard 386-2016 Fig. 15 (Interface 13: a 600 and 900 A deadbreak interface, 35 kV class) for use with 21.1/36.6 kV separable insulated connectors (Elastimold®, Eaton's Cooper Power Systems or other approved equal). The bushings shall be pressure-molded cycloaliphatic epoxy with a 1.25-inch diameter silver-plated copper conductor on the "air-insulated" side that is drilled and tapped 0.625-inch-11UNC x 1-inch deep to provide direct connection of the bus and/or live parts. Leakage distance from the apparatus connection end of the bushing to ground shall be not less than 43 inches to assure trouble-free operation in a wet and/or contaminated environment. Integral shielding shall be provided to eliminate partial discharge caused by off-center mounting and mounting holes that may have sharp edges or burrs. Bushings shall mount in a 3.125-inch diameter opening and bolt in place to allow

field replacement with standard tools. The bushing mounting bolts shall be self-locking stainless steel serrated-flange hex-head bolts that "cut" through the enclosure protective finish to ground the integral shielding of each bushing. To assure adequate strength for apparatus support, the bushing shall withstand a minimum cantilever loading of 600 pounds for five minutes without damage. The bushing interface shall be free of all voids, holes and heat sinks to assure proper mating with separable insulated connectors. Each bushing shall be tested in free air, mounted in a grounded steel plate not less than 10 inches x 10 inches, and with an insulated protective cap (Eaton's Cooper Power Systems #DPC635 or equal) installed on the interface to accurately simulate operating conditions (gas or liquid dielectric on the interface shall not be acceptable for this test). Each bushing shall meet the requirements for 35 kV devices in accordance with IEEE Standard 386 (latest revision), including 100 percent production testing.

Elastimold® is a registered trademark of ABB Asea Brown Boveri Ltd.



35-kV 200-kV BIL Apparatus Bushings

“B” Series (bolt-in) for Elbow to Air-Insulated Service
200 Amp, 600 Amp, 900 Amp and 1250 Amp

Descriptive
Bulletin
1035-230
Page 7 2019

Bushing-Style Insulator #1802-035B3

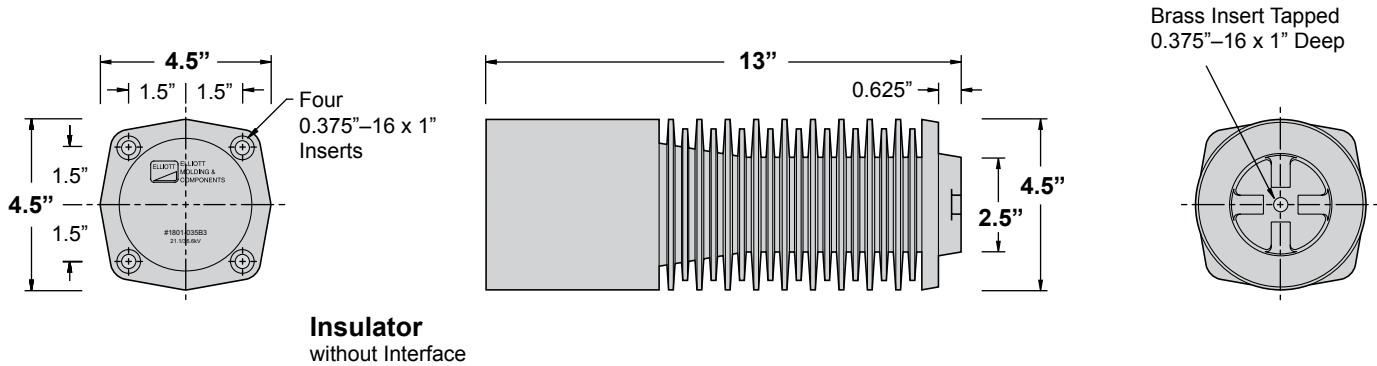

Voltage Class.....	35 kV
Phase-to-Ground Voltage.....	21.1 kV
BIL.....	200 kV
AC Withstand - 1 Min. Dry.....	75 kV
10 Sec. Dew.....	50 kV
DC Withstand - 15 Min. Dry.....	103 kV
Corona Extinction Level - Minimum.....	26 kV
Continuous Current.....	N/A
Momentary - RMS, Sym., 0.17 sec.....	N/A
RMS, Sym., 3 sec.....	N/A

Leakage Distance, Inches.....	46
Dry Arcing Distance, Inches.....	13
Mechanical - Strength Rating, Pounds	
Cantilever, Ultimate 2.5 inches past end.....	>1,000
Tensile, Pounds.....	>5,000
Torsion, Inches-Pounds (bolt breaks).....	>700
Compression, Pounds.....	20,000
Insert Thread Size.....	0.375”-16 x 1”
Live End Thread Size.....	0.375”-16 x 1”
Net Weight, Pounds (kg).....	11.95 (5.42)

Typical Specifications - 35-kV 200-kV BIL Bushing-Style Insulators

Insulators shall be Elliott #1802-035B3, 35 kV Class (21.1 kV to ground) that are mechanically interchangeable with Elliott “B” Series 35 kV Class Air-Insulated Bushings. The insulators shall be pressure-molded cycloaliphatic epoxy with 0.375-inch–16UNC x 1-inch deep threaded and knurled brass inserts cast in place. One insert is located to match the “air-insulated” end of the 200 Amp Elliott Air-Insulated Bushing Wells to provide direct connection of the bus and/or live parts. The length of the insulators shall match the length of 200 Amp, 600 Amp, 900 Amp and 1250 Amp Elliott 35 kV Class Air-Insulated Bushings. Leakage distance from the apparatus connection end of

the insulators to ground shall be not less than 43 inches to assure trouble-free operation in a wet and/or contaminated environment. Insulators shall bolt in place using the same Standard mounting holes (or Uni-Mount mounting holes) as 200 Amp, 600 Amp, 900 Amp and 1250 Amp Elliott 35 kV Class Air-Insulated Bushings. In addition, the insulators shall cover the 3.125-inch diameter opening and allow field replacement with a “B” Series insulator or bushing using standard tools. To assure adequate strength for apparatus support, the insulators shall withstand a minimum cantilever loading of 600 pounds for five minutes without damage.

Elastimold® is a registered trademark of ABB Asea Brown Boveri Ltd.

Production Tests

Every bushing is production tested in free air, mounted in an 11-gauge grounded steel plate not less than 10 inches x 10 inches, with an insulating protective plug (or cap) installed on the interface to accurately simulate operating conditions. Each bushing must meet or exceed the requirements for 21.1/36.6 kV devices in accordance with the test values of IEEE Standard 386 (latest revision) for partial discharge (corona) and 75 kV AC voltage withstand when tested in this manner.

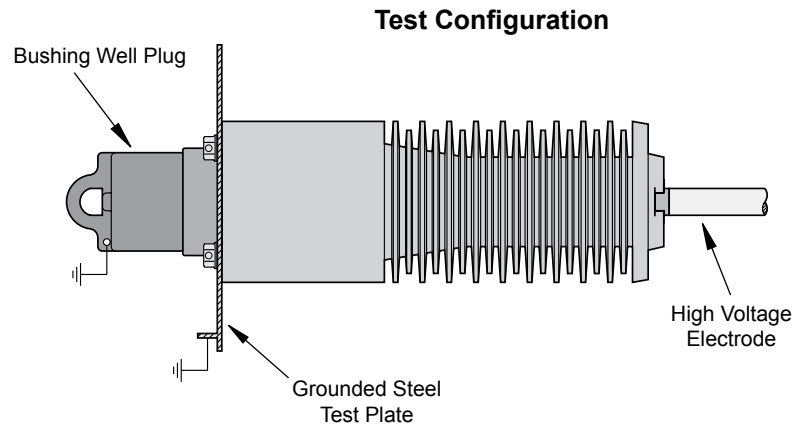

Installation Instructions

Elliott “B” Series Apparatus Bushings require a 3.125-inch diameter mounting hole with four 0.4375-inch diameter bolt holes. The bushing bolts in place utilizing four 0.375-inch–16UNC x 1-inch serrated-flange hex-head bolts (or bolts with external tooth lock washers). All mounting hardware is located on the elbow side of the equipment mounting plate to eliminate the possibility of reduced phase-to-ground clearance.

Every Elliott Bushing is tested at the factory, mounted in a grounded steel plate. A greased bushing well plug (or insulating protective cap) is installed on the interface to accurately simulate operating conditions. To prevent contamination of the silicone grease, it is important to keep the shipping cap in place until you are ready to install the bushing insert (or elbow). Should the grease become contaminated, thoroughly clean the interface and reapply silicone grease before installing the bushing insert (or elbow).

NOTE: The shipping cap on the bushing well (or bushing) should be left in place to prevent contamination of the interface.

1. The bushing installs from the rear (live) side for easy installation.
2. Serrated-flange bolts (or bolts and external tooth lock washers) are installed. The bolts should be tightened in a uniform manner (rather than one by one in a random sequence). Do not apply more than 90 inch-pounds torque to each bolt. The serrated-flange bolts (or external tooth lock washers) must “cut” into the mounting plate to provide a connection from the shielding to the grounded mounting plate. If the bushing is mounted on an ungrounded or insulated plate (such as fiberglass) a ground strap should be attached to one of the mounting bolts.

IMPORTANT:

Do not energize this bushing with only the shipping cap in place. To do so would lead to failure of this bushing and create a hazard to operating personnel. This product is designed to be used **only** when it is mated with an appropriate 35 kV Class bushing insert (or elbow) conforming to the latest revision of IEEE Standard 386. The bushing insert (or elbow) should be installed in accordance with the instructions supplied by the connector manufacturer.

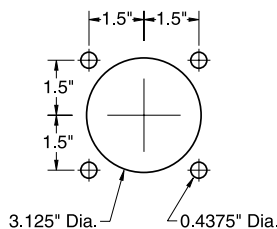

Standard Mounting Holes
for Elliott “B” Series Bushings

